

	<p>Counter Number Signage (2 sets each counter)</p> <p>16. Customer Care Center (#1-4) (8) P _____ P _____</p> <p>17. Teller Counter (#1-2) (4) P _____ P _____</p> <p>18. E-Center (#1-20) (40) P _____ P _____</p> <p>Ceiling- or Wall-mounted Signage</p> <p>19. Customer Care Center (1) P _____ P _____</p> <p>20. Teller Counter (1) P _____ P _____</p> <p>21. E-Center (1) P _____ P _____</p> <p>22. Information/ EBQS (1) P _____ P _____</p> <p>23. PACD (1) P _____ P _____</p> <p>Door- or Wall-mounted Signage</p> <p>24. Pensioner's Lounge (1) P _____ P _____</p> <p>25. MALC (1) P _____ P _____</p> <p>26. MEC (1) P _____ P _____</p> <p>27. Admin Section (1) P _____ P _____</p> <p>28. Conference Room (1) P _____ P _____</p> <p>29. AMS (1) P _____ P _____</p> <p>30. MSS Backroom (1) P _____ P _____</p> <p>31. GAD Corner (1) P _____ P _____</p> <p>32. Records & Storage Room (1) P _____ P _____</p> <p>33. Electrical & Data Cabinet Room (1) P _____ P _____</p> <p>34. Breastfeeding & Infant Care Station (1) P _____ P _____</p> <p>35. ACOP (1) P _____ P _____</p> <p>36. Supply Room (1) P _____ P _____</p> <p>37. Drinking Station (2) P _____ P _____</p> <p>38. Pantry (1) P _____ P _____</p> <p>Directional Signage</p> <p>39. Fire Extinguisher (12) P _____ P _____</p> <p>40. Emergency Exit (4) P _____ P _____</p> <p>41. Public Comfort Room (1) P _____ P _____</p> <p>42. Admin Section (1) P _____ P _____</p> <p>43. AMS (1) P _____ P _____</p> <p>44. MSS Backroom (1) P _____ P _____</p> <p>45. Restricted (4) P _____ P _____</p> <p>Horizontal Signage</p> <p>46. Storefront (4m width) (3) P _____ P _____</p> <p>47. Pylon/ Existing Frame (~1.1 X 2.4m), 2F (1) P _____ P _____</p>	
TOTAL PROJECT COST:		
Total Offered Quotation (inclusive of VAT) in words:		
Date Receipt of Request for Quotation Form		
Price Validity	Three (3) Months	
Delivery Terms	<ul style="list-style-type: none"> • Thirty (30) Calendar Days from receipt of the approved Job Order including the period for inspection and acceptance of 1 – 5 working days. 	
Payment Terms	<ul style="list-style-type: none"> • Government Terms • SSS shall withhold the applicable taxes from the amount payable in accordance with the BIR regulations. • One-time payment. • Payment is upon delivery of services and submission of billing documents; and shall be directly credited to the Supplier's bank account maintained at Land Bank of the Philippines (LBP), or bank transfer in non-LBP accounts where corresponding bank charges shall be paid by the payee. 	

Business Name: _____

Supplier's Signature: _____ Page 2 of 5

BIDDER'S INFORMATION		
Business Name	Address	
Name of Company Representative (Signature over Printed Name)	Email Address	Telephone/Mobile Number
PhilGEPS Registration No.	SS Number	BIR TIN

NOTE: The Supplier must ensure to fill-out the owner/company representative signature over printed name and business details. Incompletely filled-out RFQ Form is ground for disqualification of submitted quotation.

TERMS AND CONDITIONS

- For contract price amounting to P100,000.00 and above, the winning supplier shall be required to post a Performance Security from receipt of Notice of Award equivalent to % of Contract Price as follows:
 - 5% (Goods & Consulting Services) or 10% (Infrastructure) Cash, Cashier's/Manager's Check, Bank Draft/Guarantee, or
 - 30% Surety Bond callable upon demand
- If two (2) or more suppliers submitted the same price quotation and have been post-qualified as the suppliers with Lowest Calculated and Responsive Quotations, the procuring unit shall use "draw lots" or similar method of chance to break the tie.
- Alternative offer shall not be allowed. Any bid exceeding the ABC shall be ground for disqualification.
- Incompletely filled out Bid Breakdown shall be considered non-responsive and automatically disqualified but specifying a zero (0), dash (-), or the word "free" for the said item would mean that it is being offered for FREE to the SSS.
- In case of discrepancy between the submitted quotation and the quotation after arithmetical correction, the supplier shall be informed of such discrepancy for confirmation of the new amount. If the bidder fails to confirm the arithmetical corrections within three (3) calendar days from receipt of notification, the quotation as calculated shall be deemed confirmed.
- In case a prospective supplier/service provider submits a filled-out RFQ with a supporting document (i.e., a price quotation in a different format), both documents shall be considered provided that the terms and conditions stated therein is in conformity with the requirements of the RFQ. In case of discrepancies, the submitted quotation shall be considered ineligible or not compliant.
- Quantity is subject to change but not to exceed the quantity in the approved PO/JO/LO.
- Award shall be per " **LOT BASIS**" and date of conduct/start of the project is subject to change.

INSTRUCTIONS TO SUPPLIERS

- For clarification of details, please contact **Ms. Leianne Emili Magnifico at (048) 433-1671**.
- All documents shall be signed, and every page thereof shall be initialed, by the Owner or duly authorized representative/s of the Bidder.
- Quotations may be submitted through the following:
 - BRANCH'S ADMINISTRATIVE SECTION located at SSS Puerto Princesa Branch, G, Grandway Bldg., Eastville City Walk, San Pedro, Puerto Princesa City, Palawan.
 - ELECTRONIC MAIL at puertoprincesa@sss.gov.ph with the following requirements:
 - Quotations and attachments should be in portable document format (pdf), compressed/zipped. File name of the zip file folder shall be by RFQ number and Project Title.
- Copies of the following documentary requirements are required to submit together with the bidder's quotation prior to the recommendation of award (evaluation of offer):
 - Valid Mayor's/Business Permit;
 - PhilGEPS Registration Number (Red Membership) or PhilGEPS Certificate (Platinum Membership);
 - Certificate of Registration whichever may be appropriate under existing laws of the Philippines:
 - Bureau of Domestic Trade & Industry (DTI) – Sole Proprietorship
 - Incorporation Papers registered and approved by the Securities & Exchange Commission - Partnership/Corporation
 - Philippine Contractors Accreditation Board License (PCAB) - Contractors/Civil Works
 - Cooperative Development Authority (CDA) – Cooperatives;
 - Latest Annual Income / Business Tax Return (for ABCs above ₱500K);
 - BIR Certificate of Registration Form 2303;
 - SSS ID Number (Employer/Self-Employed);
 - Notarized Omnibus Sworn Statement with attached Notarized Special Power of Attorney (SPA) for Sole Proprietorship or Secretary's Certificate for Partnership / Corporation (for ABCs above ₱50,000.01), or Letter of Authorization / Company ID (for ABCs below ₱50,000.00), authorizing the representative, if any, to sign on behalf of the owner/company.

Note: Submitted documents are subject to verification and validation of its authenticity, genuineness, validity, and completeness. Incomplete submission, concealment, falsification, or misrepresentation of any of the documents submitted, or the contents thereof is a ground for disqualification of submitted quotation.

GENERAL CONDITIONS OF THE CONTRACT

- The SUPPLIER shall deliver the goods in accordance with the description and quantity specifications of the Purchase Order/Job Order.
- The SUPPLIER shall deliver the goods within the period indicated in the Purchase Order. A penalty of 1/10 of 1% of the total amount of the items shall be imposed for every day of delay in delivery.
- The SUPPLIER shall deliver Goods/Services which must all be fresh stock, brand-new, unused, properly sealed, and which are not set to expire within two (2) years from date of delivery to the SSS, if applicable.

Business Name: _____

Supplier's Signature: _____ Page 3 of 5

4. The SUPPLIER warrants that all the Goods/Services have no defects arising from design, materials, or workmanship or from any act or omission of the Supplier or the manufacturer that may develop under normal use of consumables, if applicable.
5. For Goods, the SUPPLIER shall replace any defective item within twenty-four (24) hours from the time that it was notified by the SSS of the defect. Defects detected only after the item is installed and used are covered by the replacement warranty which will be in effect for every item until its expiry date. Replacement of defective item shall have no cost to the SSS, if applicable.
6. To assure that manufacturing defects shall be corrected by the SUPPLIER, a warranty security shall be required from the SUPPLIER for a minimum of three (3) months, in the case of expendable items or a minimum period of one (1) year, in the case of non-expendable items, after the acceptance of the delivered items. The obligation for the warranty shall be covered, at the Supplier's option, by either retention money in an amount equivalent to five percent (5%) of total purchase price, or a special bank guarantee equivalent to five percent (5%) of the total purchase price with validity period starting from the date of acceptance. The said amounts shall only be released after the lapse of the warranty period
7. If the SUPPLIER, having been notified, fails to remedy the defect(s) within the specified period, the SSS may proceed to take such remedial action as may be necessary, at the SUPPLIER's risk and expense and without prejudice to any other rights which the SSS may have against the SUPPLIER under these Terms and Conditions and under the applicable law.
8. The pricing of the Goods/Services shall be in Peso and inclusive of Twelve Percent (12%) Value-Added Tax (VAT).

MISCELLANEOUS PROVISIONS

1. **Confidentiality.** Neither Party shall, without the prior written consent of the other, disclose or make available to any person, make public, or use directly or indirectly, except for the performance and implementation of the works, any confidential information acquired from an information holder in connection with the performance of this Agreement, unless: (i) the information is known to the disclosing Party, as evidenced by its written records, prior to obtaining the same from the information holder and is not otherwise subject to disclosure restrictions on the disclosing Party, (ii) the information is disclosed to the disclosing Party by a third party who did not receive the same, directly or indirectly, from an information holder, and who has no obligation of secrecy with respect thereto, or (iii) required to be disclosed by law. The obligation of confidentiality by both Parties, as provided herein, shall survive the termination of this Agreement.
2. **Merger and Consolidation.** In case of merger, consolidation or change of ownership of the SUPPLIER with another company, it is the responsibility of the surviving company/consolidated company/acquiring entity to inform the SSS of the change in corporate structure/ownership. Failure to do so shall translate in such company assuming all liabilities of the acquired/merged company under this Agreement.
3. **Force Majeure.** The SUPPLIER shall not be liable for forfeiture of its performance security, liquidated damages, or termination for default if and to the extent that the SUPPLIER's delay in performance or other failure to perform its obligations under this Agreement is the result of a force majeure. For purposes of this Agreement the terms "force majeure" and "fortuitous event" may be used interchangeably. In this regard, a fortuitous event or force majeure shall be interpreted to mean an event which the SUPPLIER could not have foreseen, or which though foreseen, was inevitable. It shall not include ordinary unfavorable weather conditions; and any other cause the effects of which could have been avoided with the exercise of reasonable diligence by the SUPPLIER. Such events may include, but not limited to, acts of the SSS in its sovereign capacity, wars or revolutions, fires, floods, epidemics, quarantine restrictions, and freight embargoes.
4. **Non-Assignment.** Neither Party may assign the Contract in whole or in part without the consent of the other Party.
5. **Waiver.** Failure by either Party to insist upon the other the strict performance of any of the terms and conditions hereof shall not be deemed a relinquishment or waiver of any subsequent breach or default of the terms and conditions hereof, which can only be deemed made if expressed in writing and signed by its duly authorized representative. No such waiver shall be construed as modification of any of the provisions of this Agreement or as a waiver of any past or future default or breach hereof, except as expressly stated in such waiver.
6. **Cumulative Remedies.** Any and all remedies granted to the Parties under the applicable laws and this Agreement shall be deemed cumulative and may, therefore, at the sole option and discretion, be availed of by the aggrieved Party simultaneously, successively, or independently.
7. **No Employer-Employee Relationship.** It is expressly and manifestly understood and agreed that the employees of the SUPPLIER assigned to perform the PROJECT are not employees of the SSS. Neither is there an employer-employee relationship between the SSS and the SUPPLIER. This Agreement does not create an employer-employee relationship between the SSS and the SUPPLIER including its personnel; that the PROJECT rendered by the personnel assigned by the SUPPLIER to the SSS in the performance of its obligation under this Agreement do not represent government service and will not be credited as such; that its personnel assigned to the SSS are not entitled to benefits enjoyed by SSS' officials and employees such as Personal Economic Relief Allowance (PERA), Representation and Transportation Allowance (RATA), ACA, etc.; that these personnel are not related within the third degree of consanguinity or affinity to the contracting officer and appointing authority of the SSS; that they have not been previously dismissed from the government service by reason of an administrative case; that they have not reached the compulsory retirement age of sixty-five (65); and that they possess the education, experience and skills required to perform the job. The SUPPLIER hereby acknowledges that no authority has been given by the SSS to hire any person as an employee of the latter. Any instruction given by the SSS or any of its personnel to the SUPPLIER's employees is to be construed merely as a measure taken by the former to ensure and enhance the quality of PROJECT performed hereunder. The SUPPLIER shall, at all times, exercise supervision and control over its employees in the performance of its obligations under this Agreement.
8. **Partnership.** Nothing in this Agreement shall constitute a partnership between the parties. No Party or its agents or employees shall be deemed to be the agent, employee or representative of any other Party.

Business Name: _____

Supplier's Signature: _____ Page 4 of 5

9. **Compliance with SS Law.** The SUPPLIER shall report all its employees to the SSS for coverage and their contributions, as well as all amortizations for salary/education/calamity and other SSS loans shall be updated. Should the SUPPLIER fail to comply with its obligation under the provisions of the SS Law and Employees' Compensation Act, the SSS shall have the authority to deduct any unpaid SS and EC contributions, salary, educational, emergency and/or calamity loan amortizations, employer's liability for damages, including interests and penalties from the SUPPLIER's receivables under this Agreement. Further, prescription does not run against the SSS for its failure to demand SS contributions or payments from the SUPPLIER. Moreover, the SUPPLIER shall forever hold in trust SS contributions or payments of its employees until the same is fully remitted to the SSS.
10. **Compliance with Labor Laws.** The SUPPLIER, as employer of the personnel assigned to undertake the PROJECT, shall comply with all its obligations under existing laws and their implementing rules and regulations on the payment of minimum wage, overtime pay, and other labor-related benefits as well as remittances or payment of the appropriate amount or contributions/payment (SSS, EC, Pag-IBIG, PhilHealth and taxes) with concerned government agencies/offices.

It is agreed further, that prior to the release of any payment by the SSS to the SUPPLIER, its President or its duly authorized representative, shall submit a sworn statement that all moneys due to all the employees assigned to the PROJECT as well as benefits by law and other related labor legislation have been paid by the SUPPLIER and that he/she assumed full responsibility thereof.

11. **Compliance with Tax Laws.** The SUPPLIER shall, in compliance with tax laws, pay the applicable taxes in full and on time and shall regularly present to the SSS within the duration of this Agreement, tax clearance from the Bureau of Internal Revenue (BIR) as well as copy of its income and business tax returns duly stamped by the BIR and duly validated with the tax payments made thereon, if applicable. Failure by the SUPPLIER to comply with the foregoing shall entitle the SSS to suspend payment of the Contract Price.
12. **Liquidated Damages.** If the SUPPLIER fails to satisfactorily deliver any or all of the Goods and/or to perform the Services within the period(s) specified in the PBD inclusive of duly granted time extensions if any, the SSS shall, without prejudice to its other remedies under this Agreement and under the applicable law, deduct from the Contract Price, as liquidated damages, the applicable rate of one tenth (1/10) of one (1) percent of the cost of the unperformed portion for every day of delay until actual delivery or performance. Once the amount of liquidated damages reaches ten percent (10%), the SSS may rescind or terminate this Agreement, without prejudice to other courses of action and remedies open to it.
13. **Hold Free and Harmless.** The SUPPLIER agrees to defend, indemnify, and hold the SSS free and harmless from any and all claims, damages, expenses, fines, penalties and/or liabilities of whatever nature and kind, whether in law or equity, that may arise by reason of the implementation of the Agreement. In addition, the SUPPLIER agrees to indemnify the SSS for any damage as a result of said implementation.
14. **Settlement of Disputes.** All actions and controversies that may arise from the Contract involving but not limited to demands for specific performance of the obligations as specified herein and/or in the interpretation of any provisions or clauses contained herein, shall, in the first instance, be settled within thirty (30) calendar days through amicable means, such as, but not limited to mutual discussion. Should the dispute remain unresolved by the end of the aforementioned period, the dispute shall be settled in accordance with applicable provisions of Republic Act No. 9285, otherwise known as the Alternative Dispute Resolution Act of 2004.
15. **Venue of Actions.** Any suit or proceeding arising out of relating to the contract shall be instituted in the appropriate court in Quezon City, parties hereto waiving any other venue.
16. **Governing Law.** This Agreement shall be governed by and interpreted according to the laws of the Republic of the Philippines.
17. **Amendments.** This Agreement may be amended only in writing and executed by the Parties or their duly authorized representatives.
18. **Separability.** If any one or more of the provisions contained in this Agreement or any document executed in connection herewith shall be invalid, illegal or unenforceable in any respect under any applicable law, then: (i) the validity, legality and enforceability of the remaining provisions contained herein or therein shall not in any way be affected or impaired and shall remain in full force and effect; and (ii) the invalid, illegal or unenforceable provision shall be replaced by the parties immediately with a term or provision that is valid, legal and enforceable and that comes closest to expressing the intention of such invalid, illegal or unenforceable term or provision.
19. **Binding Effect.** This Agreement shall be binding upon the Parties hereto, their assignee/s and successor/s-in-interest.
20. **Non-Publicity.** No press release in oral, written or electronic form shall be issued covering this transaction without prior written approval of the SSS. Inclusion in any reference lit shall also be undertaken only upon prior written approval of the SSS.

CERTIFICATION

This is to certify that my company conforms with the above Terms and Conditions, and that the data/quotation indicated are true, correct, and valid.

Owner/Company Representative
(Signature over Printed Name)

Date

Business Name: _____

Supplier's Signature: _____

BILL OF QUANTITIES

**PROJECT : SUPPLY, DELIVERY & INSTALLATION OF SIGNAGES FOR SSS PUERTO PRINCESA BRANCH,
BROOKE'S POINT, TAYTAY AND ROBINSONS PLACE PALAWAN SERVICE OFFICES**

Item#	Description	Quantity	Unit Price	TOTAL
	<i>Backdrop Wall</i>			
1	Customer Care Center (w/ SSS logo)	1		
	<i>Glass Door Vinyl Sticker Cut-out</i>			
2	Office of the Branch Head	1		
3	Office Hours	2		
4	Medical Evaluation Center	1		
	<i>Frosted Glass Sticker for MEC</i>			
5	1.2 X 1.65 M	1		
6	1.2 X 5 M	1		
	<i>Glass-mounted Signage</i>			
7	No Firearms Allowed Inside	3		
8	No Vendors & Peddlers Allowed Inside	3		
9	Work Suspension	5		
10	Next Counter Please	6		
11	OFFLINE	5		
	<i>Toilet Door-mounted Signage</i>			
12	Men's Toilet	1		
13	Women's Toilet	1		
14	Universal Toilet	2		
15	Workstation Nameplates	35		
	<i>Counter Number Signage (2 sets each counter)</i>			
16	Customer Care Center (#1-4)	8		
17	Teller Counter (#1-2)	4		
18	E-Center (#1-20)	40		
	<i>Ceiling- or Wall-mounted Signage</i>			
19	Customer Care Center	1		
20	Teller Counter	1		
21	E-Center	1		
22	Information/ EBQS	1		
23	PACD	1		
	<i>Door- or Wall-mounted Signage</i>			
24	Pensioner's Lounge	1		
25	MALC	1		
26	MEC	1		
27	Admin Section	1		
28	Conference Room	1		
29	AMS	1		
30	MSS Backroom	1		
31	GAD Corner	1		
32	Records & Storage Room	1		
33	Electrical & Data Cabinet Room	1		
34	Breastfeeding & Infant Care Station	1		
35	ACOP	1		
36	Supply Room	1		
37	Drinking Station	2		
38	Pantry	1		
	<i>Directional Signage</i>			
39	Fire Extinguisher	12		
40	Emergency Exit	4		
41	Public Comfort Room	1		

42	Admin Section	1		
43	AMS	1		
44	MSS Backroom	1		
45	Restricted	4		
	Horizontal Signage			
46	Storefront (4m width)	3		
47	Pylon/ Existing Frame (~1.1 X 2.4m), 2F	1		
		169	GRAND TOTAL	

Submitted by:

(Name of Bidder/Company Name)

Prepared by:

(Company Representative – Signature over Printed Name)

Address: _____

Contact No.:

Date:

TECHNICAL SPECIFICATIONS

Bidders should indicate "COMPLY" or "NOT COMPLY" to the specifications/requirements below.

SUPPLY, DELIVERY & INSTALLATION OF SIGNAGES AT SSS PUERTO PRINCESA BRANCH, BROOKE'S POINT, TAYTAY & ROBINSONS PLACE PALAWAN SERVICE OFFICES

Item	Specification	Statement of Compliance
<p style="text-align: center;">1</p> <p>Indoor Directional Signage</p>	<p>Single-Face Signage</p> <ul style="list-style-type: none"> ▪ Signage Panel - 3mm thick acrylic sheet base with 2mm thick clear acrylic sheet cover ▪ Vinyl Sticker, 3M vinyl sticker or equivalent: Background - Cerulean cascade blue hex: #2B4F9B or similar color, Pattern - Marine Mirage hex: #387386 or similar color ▪ Font - Montserrat ▪ Text Height - 25mm <p>Double-Face Signage</p> <ul style="list-style-type: none"> ▪ Signage Panel - 4.5 mm thick acrylic sheet base with back-to-back vinyl sticker background, pattern and top/cover ▪ Vinyl Sticker, 3M vinyl sticker or equivalent: Background - Cerulean cascade blue hex: #2B4F9B or similar color, Pattern - Marine Mirage hex: #3873B6 or similar color, Top/Cover - clear vinyl sticker ▪ Font - Montserrat ▪ Text Height - 25mm <p>Mounting</p> <ul style="list-style-type: none"> ▪ Projection/Overhang - Stainless steel projecting stand-off bolt or matte black metal bracket ▪ Wall/Door-Mounted - Heat-resistant double-sided tape, heavy-duty ▪ Ceiling-Mounted - Stainless steel ceiling-mounted cable signage hanger with adjustable clip/clamp 	
<p style="text-align: center;">2</p> <p>Customer Care Center Backdrop Wall Signage</p>	<p>SSS Logo</p> <p>Built-up logo - 3mm thick white acrylic sheet logo with opaque white acrylic sheet siding, with LED backlight</p> <ul style="list-style-type: none"> ▪ Size - 639mm (W) x 500mm (H) <p>"SOCIAL SECURITY SYSTEM"</p> <ul style="list-style-type: none"> ▪ Built-up letters in 3mm thick acrylic sheet with LED backlight ▪ Font - Eras BD BT ▪ Text Height - 120mm ▪ Letter Face - 3mm laser-cut acrylic sheet, white ▪ Letter Side - 3mm laser-cut acrylic sheet, opaque white <p>Painting Works – refer to Drawings</p> <p>Fluted Panels – refer to Drawings</p>	

<p>3</p> <p>Glass-Mounted Signage</p>	<ul style="list-style-type: none"> ▪ Base - 3mm thick white acrylic sheet ▪ Vinyl Sticker - Cerulean Cascade blue background (or similar color) with cut-out letters, 3M vinyl sticker or equivalent ▪ Size - 120mm (W) x 300mm (H) ▪ Cover - Laminated clear vinyl sticker ▪ Font - Montserrat ▪ Text Height - 20mm ▪ Mounting - Suction hook or clear double-sided adhesive tape, heavy-duty, 3M adhesive or its equivalent 	
<p>4</p> <p>Door-Mounted Signage</p>	<ul style="list-style-type: none"> ▪ Base - 3mm thick white acrylic sheet ▪ Vinyl Sticker - Cerulean Cascade blue background with cut-out letters/figures, 3M vinyl sticker or equivalent ▪ Size - 200mm (W) x 200mm (H) ▪ Cover - 2mm thick clear acrylic sheet ▪ Font - Montserrat ▪ Text Height - 25mm ▪ Mounting 1/4" diameter stand-off bolt, stainless steel 	
<p>5</p> <p>Counter Number Signage</p>	<p>Background Panel</p> <ul style="list-style-type: none"> ▪ Base - 3mm thick white acrylic sheet ▪ Vinyl Sticker, 3M vinyl sticker or equivalent: 1st Layer/Background - Cerulean Cascade blue hex: #2B4F9B or similar color 2nd Layer/Pattern - Marine Mirage hex: #3873B6 or similar color 3rd Layer/Top cover - clear vinyl sticker <p>Number Panel</p> <ul style="list-style-type: none"> ▪ Base: 3mm thk white acrylic sheet, 150mm (W) x 150mm (H) ▪ Font: Montserrat ▪ Number Height: 30mm ▪ Font Color: Cerulean Cascade blue hex: #2B4F9B or similar color, 3M vinyl sticker or equivalent w/ top cover - clear vinyl sticker <p>Mounting</p> <ul style="list-style-type: none"> ▪ Heat-resistant double-sided adhesive tape, 3M adhesive or its equivalent 	
<p>6</p> <p>Counter Name Tag</p>	<p>Name Tag Holder</p> <ul style="list-style-type: none"> ▪ Holder - 1mm thick folded clear acrylic sheet with 50mm (D) folded base and pen holder ▪ Size 200mm (W) x 80mm (H) ▪ Mounting - Heat-resistant double-sided adhesive tape, 3M adhesive or its equivalent 	

	<p>Printed Insert</p> <ul style="list-style-type: none"> ▪ Printed name tag on white plain board paper with Nakpil pattern ▪ Name: 14mm H (varies), Montserrat Bold, Cerulean Cascade blue text ▪ Position: 8mm H (varies), Montserrat Bold, Cerulean Cascade blue text 	
<p>7</p> <p>Outdoor Horizontal Signage</p>	<ul style="list-style-type: none"> ▪ Signage Panel/Box - 4mm thick aluminum composite panels in Cerulean Cascade Blue color, with aluminum sub-framing and accessories ▪ Panel Dimension (minimum) - 100mm (D) x 4000 mm (W) x 800 mm (H) ▪ Logo - 50mm thick built-up white acrylic sheet logo with opaque white acrylic siding and LED light backlighting ▪ Text - 50mm thick built-up white acrylic sheet letters with opaque white acrylic siding and LED light backlighting ▪ Text Caption - "SOCIAL SECURITY SYSTEM" in Eras BD BT Font, 150mm (H); "Branch Name" in Montserrat Font, 100mm (H) ▪ Acrylic sheet - 3mm thick 	
<p>8</p> <p>Outdoor Horizontal Signage (Pylon-mounted)</p>	<ul style="list-style-type: none"> ▪ Signage Panel/Box* - 4mm thick aluminum composite panels in Cerulean Cascade Blue color, with aluminum sub-framing and accessories ▪ Panel/Box Dimension * - 100mm (D) x 2400 mm (W) x 1000 mm (H) ▪ Logo - 50mm thick built-up white acrylic with opaque white acrylic siding and LED light backlighting ▪ Text - 50mm thick built-up white acrylic letters with opaque white acrylic siding and LED light backlighting ▪ Text Caption: "SOCIAL SECURITY SYSTEM" in Eras BD BT Font, 150mm (H); "Branch Name" in Montserrat Font, 100mm (H) <p><i>* Dimension may vary and/or may be printed on panaflex sheet, as may be required for signage pylon at the Branch site/location</i></p>	

Owner/Authorized Representative
(Signature Over Printed Name)

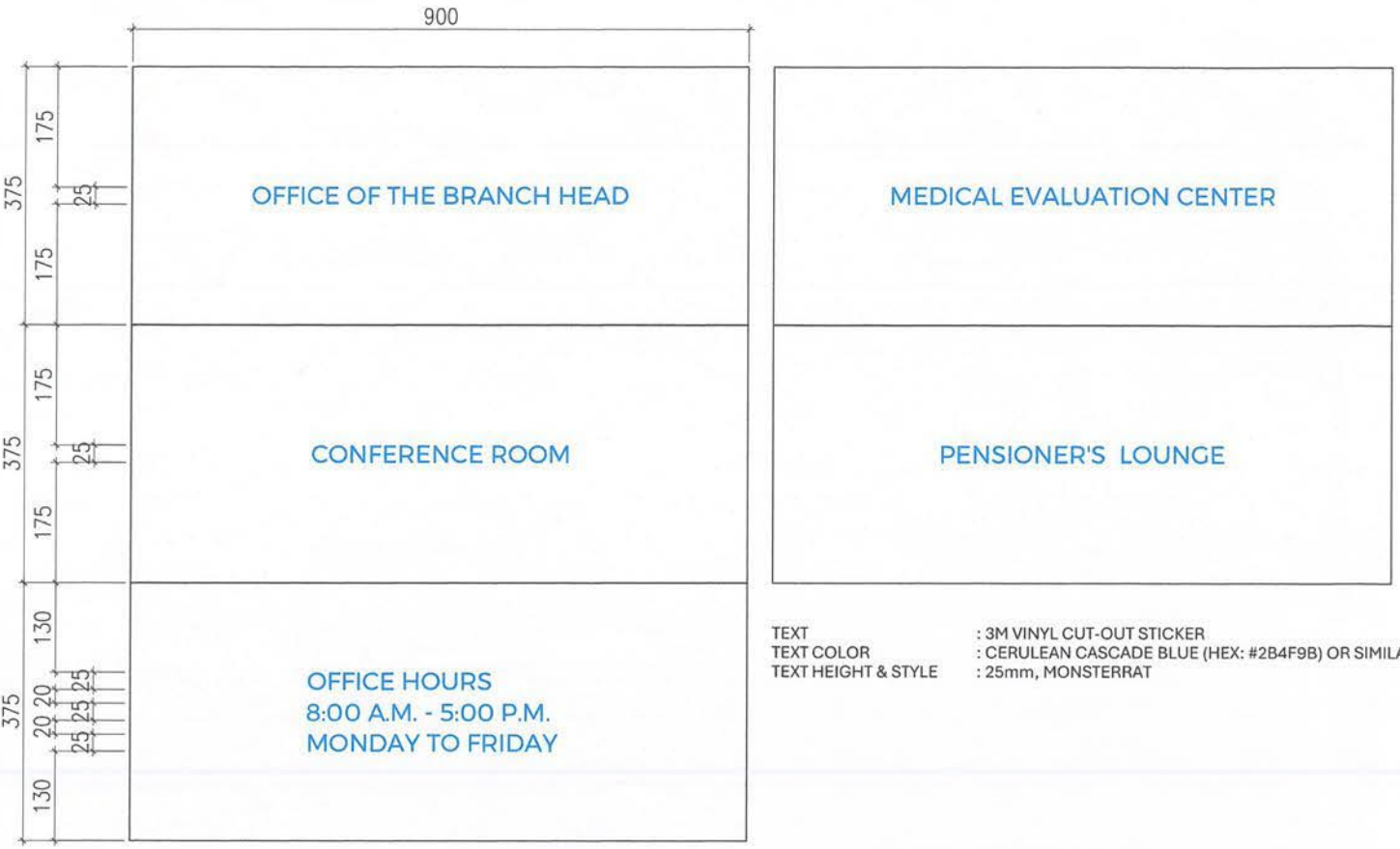

TEXT : 3M VINYL CUT-OUT STICKER
 TEXT COLOR : CERULEAN CASCADE BLUE (HEX: #2B4F9B) OR SIMILAR
 TEXT HEIGHT & STYLE : 25mm, MONSERRAT

GLASS DOOR SIGNAGE - VINYL STICKER CUT-OUT

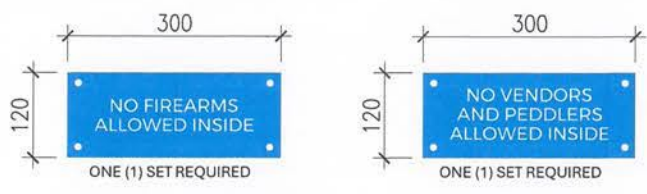

GLASS MOUNTED SIGNAGE:
 SIZE : 120mm W X 300mm H
 BASE : 3mm thk WHITE ACRYLIC PLASTIC
 COVER : LAMINATED CLEAR VINYL STICKER
 CONTENT : 3M VINYL STICKER w/ CERULEAN CASCADE BACKGROUND and WHITE w/ CUT-OUT LETTERS
 TEXT HEIGHT & STYLE : 18mm H, MONSERRAT
 MOUNTING : SUCTION HOOK TO BE MOUNTED ON ENTRANCE GLASS DOOR OR HEAVY DUTY CLEAR, DOUBLE SIDED ADHESIVE TAPE

GLASS MOUNTED SIGNAGE - STOREFRONT



DOOR MOUNTED SIGNAGES
 SIZE : 200mm W X 200mm H
 BASE : 3mm thk ACRYLIC PLASTIC - CERULEAN CASCADE BLUE
 COVER : 2mm THK CLEAR ACRYLIC PLASTIC
 CONTENT : 3M VINYL STICKER w/ CERULEAN CASCADE BACKGROUND and WHITE w/ CUT-OUT FIGURES
 FIGURES : 120 mm HEIGHT
 ANCHOR : 1/4 Ø STAND-OFF BOLT , stainless steel FINISH

TOILET DOOR MOUNTED SIGNAGE

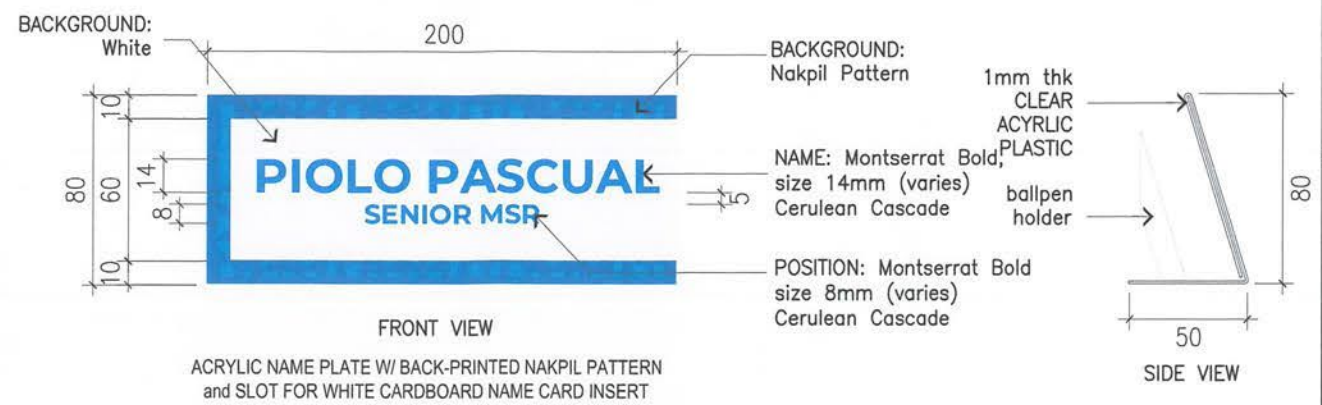

FRONT VIEW
 ACRYLIC NAME PLATE W/ BACK-PRINTED NAKPIL PATTERN and SLOT FOR WHITE CARDBOARD NAME CARD INSERT

COUNTER NAME PLATE

- Use 1mm THK CLEAR ACRYLIC PLASTIC folded to hold the inserted printed name plate and provide a flat base mount with double adhesive tape.
- Use base part to place ballpen holder
- Use double adhesive tape for mounting on countertop

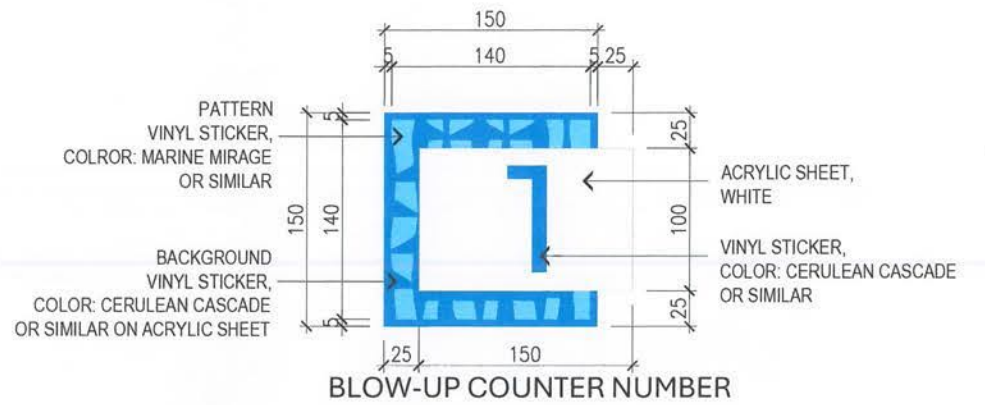

BLOW-UP COUNTER NUMBER

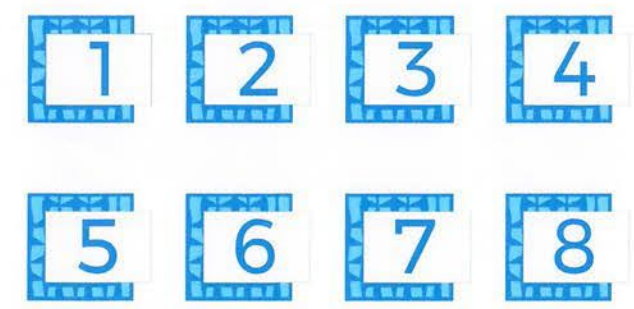

BACKGROUND PANEL
 BASE : 150mm X 150mm, 3mm WHITE ACRYLIC PLASTIC SHEET
 1ST LAYER : VINYL STICKER, MARINE MIRAGE HEX: #3873B6 OR SIMILAR
 2ND LAYER : VINYL STICKER, CERULEAN CASCADE BLUE HEX: #2B4F9B OR SIMILAR
 3RD LAYER : VINYL STICKER, CLEAR (TOP COVER)

NUMBER PANEL
 BASE : 150mm X 100mm, 3mm WHITE ACRYLIC PLASTIC BASE.
 NUMBER : VINYL STICKER, IN CERULEAN CASCADE COLOR HEX: #2B4F9B OR SIMILAR 30mm HIGH, MONSERRAT NUMBER (CUT-OUT) with CLEAR VINYL STICKER (TOP COVER)

LOCATION : SIDE PANEL, CUSTOMER CARE & TELLER COUNTER
 MOUNTING : HEAT RESISTANT DOUBLE SIDED TAPE

* 2 SETS EACH COUNTER
 * NUMBERING VARIES PER BRANCH CATEGORY

COUNTER NUMBER SIGNAGE

DETAILS OF INDOOR SIGNAGES

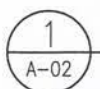

SCALE 1:10 M.

*VERIFY ACTUAL SITE CONDITION, REQUIREMENTS & LOCATION OF SIGNAGE
 *CERULEAN CASCADE & MARINE MIRAGE COLOR OR SIMILAR (MUST SUBMIT SAMPLE FOR APPROVAL)

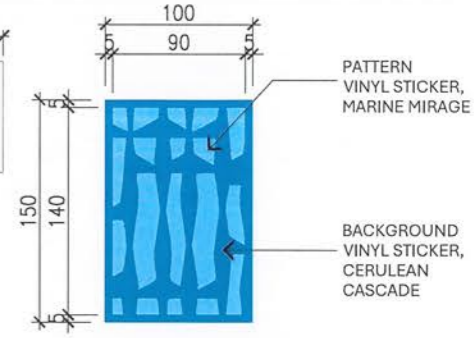
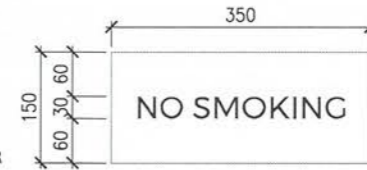
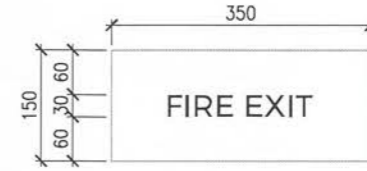
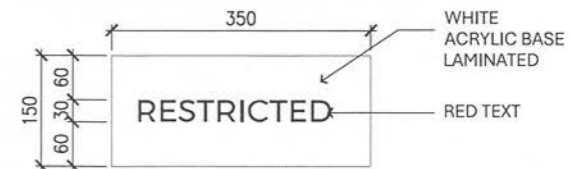
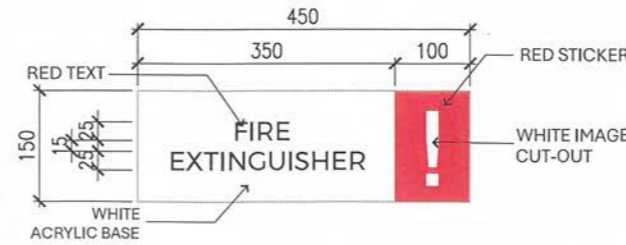
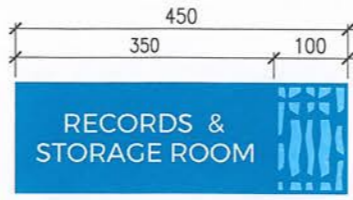
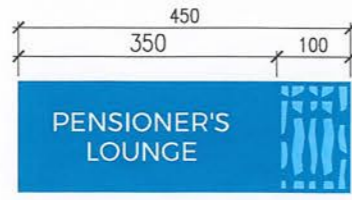
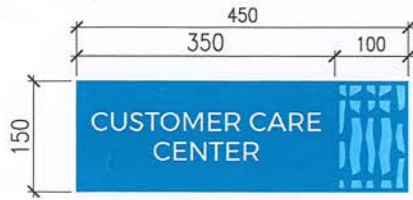

DIRECTIONAL SIGNAGES

PATTERN

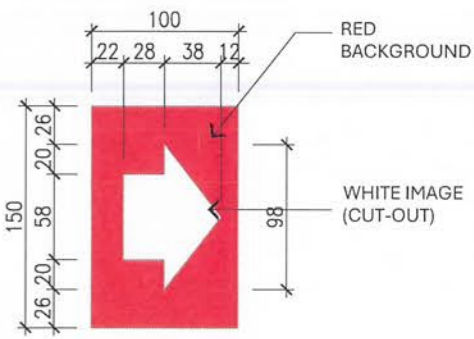
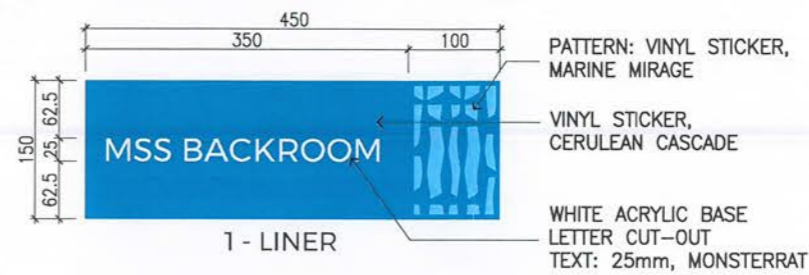

DIRECTIONAL ARROW

- MOUNTING**
1. WALL : 1/4" Ø STAND-OFF BOLT , STAINLESS STEEL
 2. WALL PROJECTING : STAND-OFF BOLT , STAINLESS STEEL
 3. CEILING : STAINLESS STEEL CEILING-MOUNTED CABLE SIGNAGE HANGER W/ ADJUSTABLE CLIP/CLAMP
- *VERIFY ACTUAL CONDITION & REQUIREMENT

CEILING/WALL MOUNTED SIGNAGES



WALL & DOOR MOUNTED SIGNAGES

- SINGLE FACE SIGNAGE**
SIGNAGE PANEL : 3mm thk WHITE ACRYLIC SHEET BASE w/ 2mm thk CLEAR ACRYLIC SHEET COVER
- DOUBLE FACE SIGNAGE**
SIGNAGE PANEL : 4.5mm thk WHITE ACRYLIC SHEET BASE w/ BACK TO BACK VINYL STICKER BACKGROUND, PATTERN, AND TOP/COVER
- VINYL STICKER** : 3M VINYL STICKER OR EQUIVALENT
 1. BACKGROUND - CERULEAN CASCADE BLUE HEX: #2B4F9B OR SIMILAR
 2. PATTERN - MARINE MIRAGE HEX: #3873B6 OR SIMILAR
 FONT : 25mm HIGH, MONTSERRAT FONT (CUT-OUT)
- MOUNTING (VARIES)**
 1. PROJECTION/OVERHANG : STAINLESS STEEL PROJECTING STAND OFF BOLT OR MATTE BLACK METAL BRACKET
 2. WALL/DOOR MOUNTED : HEAT-RESISTANT DOUBLE-SIDED TAPE, HEAVY DUTY
 3. CEILING MOUNTED : STAINLESS STEEL CEILING-MOUNTED CABLE SIGNAGE HANGER W/ ADJUSTABLE CLIP/CLAMP

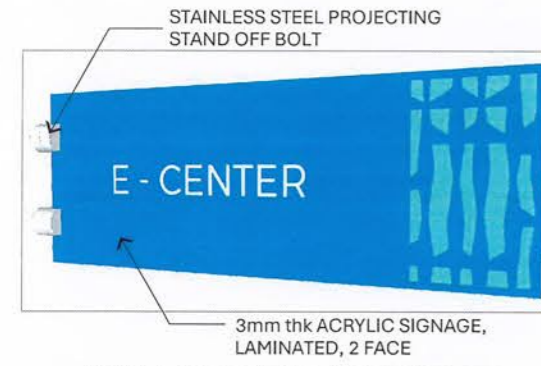

WALL PROJECTING SIGNAGE

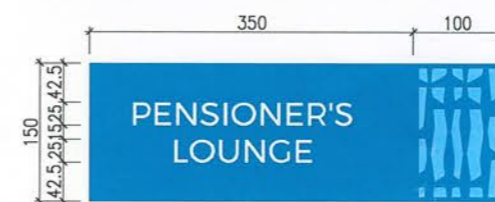

1 - LINER

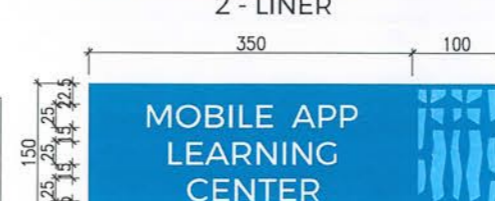

2 - LINER

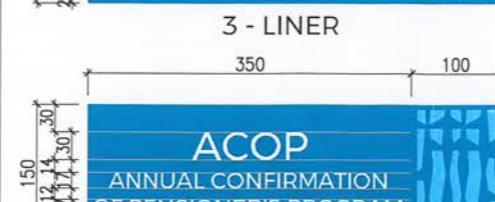

3 - LINER

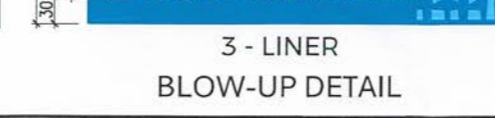

3 - LINER

BLOW-UP DETAIL

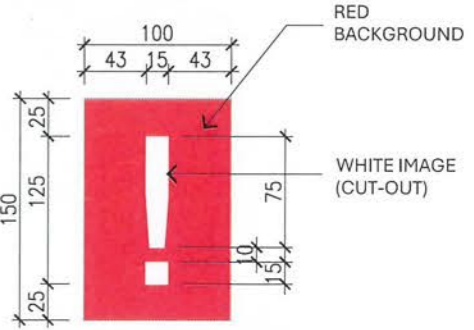

EXCLAMATION POINT

DETAILS OF INDOOR SIGNAGES

1
A-03

SCALE 1:10 M.

*VERIFY ACTUAL SITE CONDITION, REQUIREMENTS & LOCATION OF SIGNAGE
 *CERULEAN CASCADE & MARINE MIRAGE COLOR OR SIMILAR (MUST SUBMIT SAMPLE FOR APPROVAL)

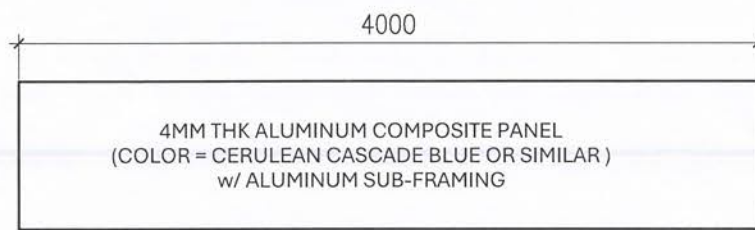
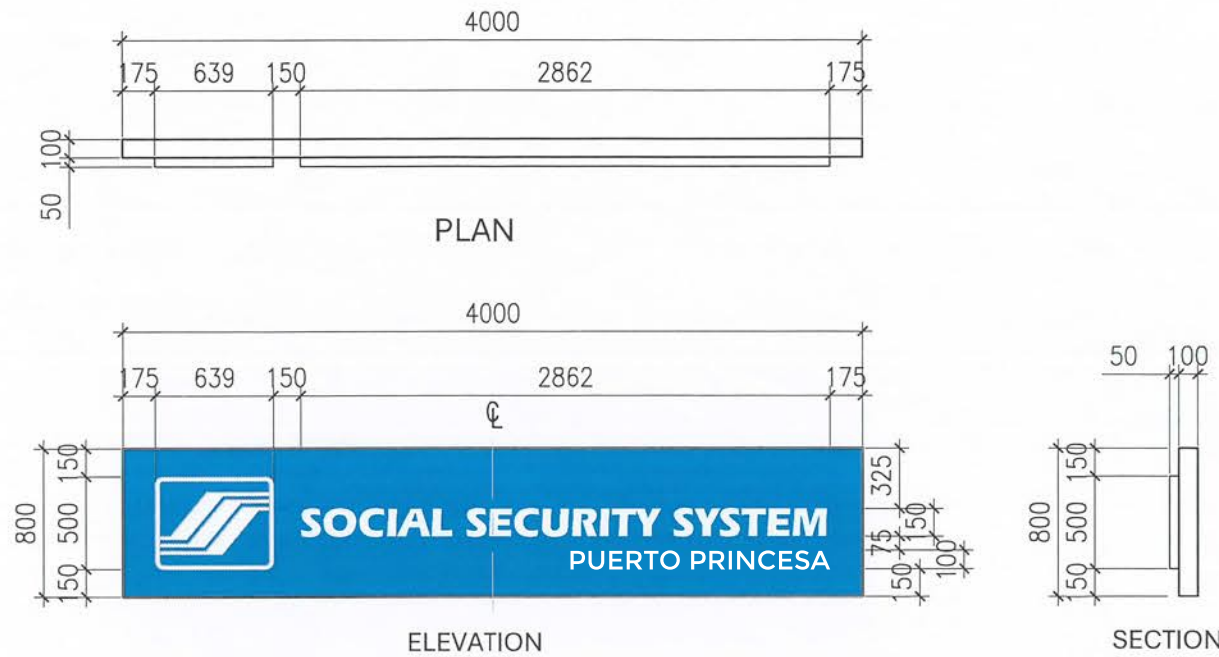

FRAME DETAILS

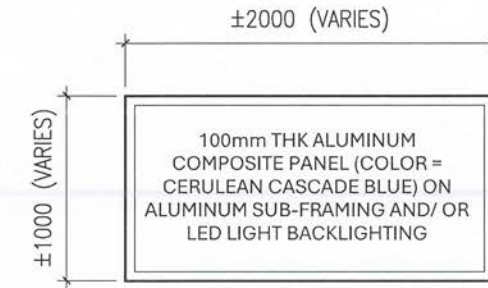
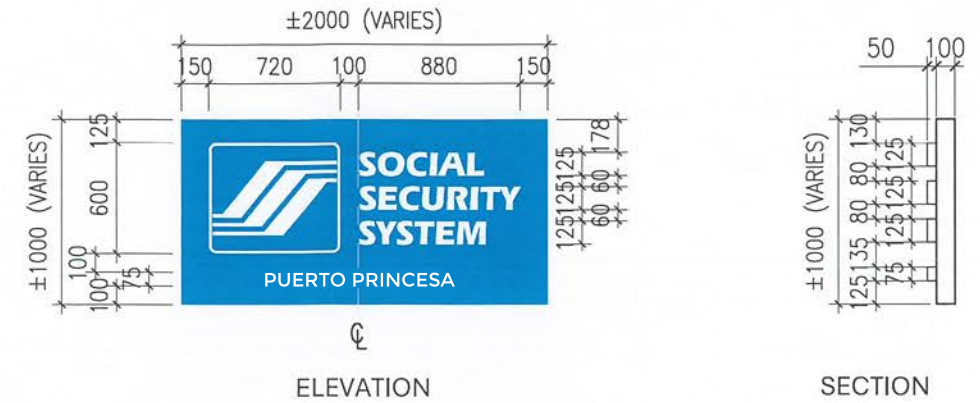

FRAME DETAILS

SOCIAL SECURITY SYSTEM

50MM THK BUILT-UP ACRYLIC LETTERS (COLOR = WHITE)
WITH PAINTED ACRYLIC SIDING
(FONT = ERAS BD BT) (SIZE = 150)
AND LED LIGHT BACKLIGHTING

PUERTO PRINCESA

50MM THK BUILT-UP ACRYLIC LETTERS (COLOR = WHITE)
WITH OPAQUE ACRYLIC SIDING
(FONT = MONTSERRAT) (SIZE = 100)
AND LED LIGHT BACKLIGHTING

SIGNAGE TEXT DETAILS

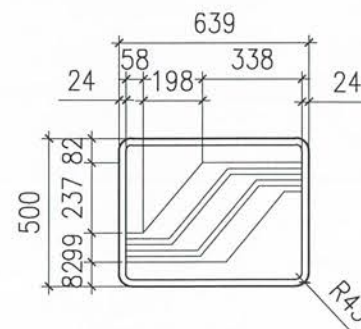

BUILT-UP ACRYLIC LOGO (COLOR = WHITE)
w/ OPAQUE ACRYLIC SIDING & LED LIGHT BACKLIGHTING

LOGO DETAILS
SCALE 1:25 m

SIGNAGE PANEL (VARIES)

1. PRINTED CERULEAN CASCADE BLUE FINISH ON 4mm THK PANAFLEX SHEET
2. 100mm THK ALUMINUM COMPOSITE PANEL WITH ALUMINUM COMPOSITE SIDING

SSS AND LOGO SIGNAGE (VARIES)

1. PRINTED WHITE FINISH ON 4mm THK PANAFLEX SHEET
2. 100mm THK ACRYLIC BUILD-UP WITH OPAQUE ACRYLIC SIDING

MOUNTING (VARIES BASED ON MALL'S EXISTING PYLON)

1. WELDED/ BOLTED
2. ATTACHED WITH BRACKETS

1 HORIZONTAL SIGNAGE (SINGLE FACE)
A-04 SCALE 1:40 M.

2 HORIZONTAL SIGNAGE (PYLON)
A-04 SCALE 1:40 M.

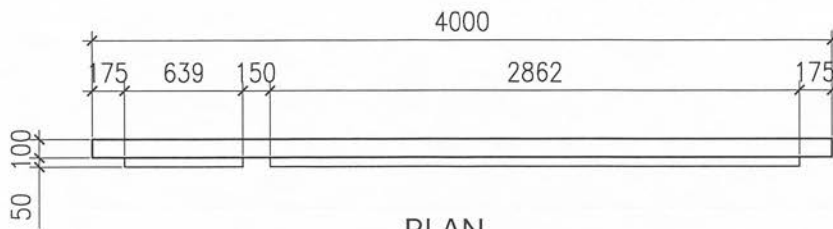

PLAN

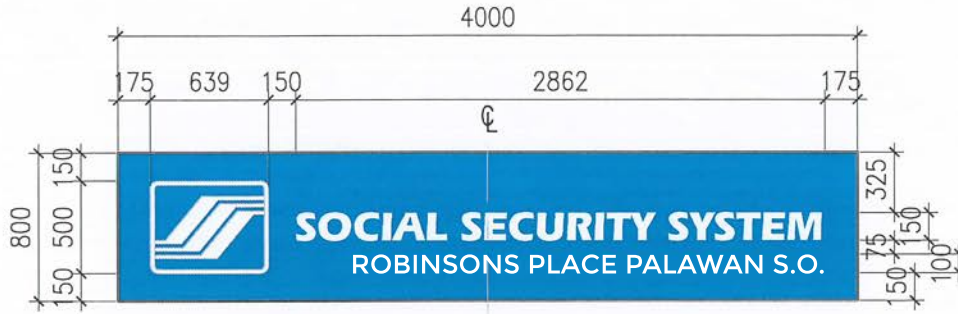

ELEVATION

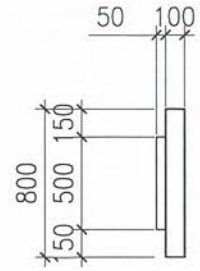

SECTION

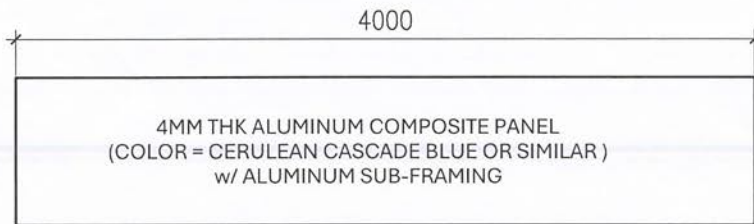

FRAME DETAILS

SOCIAL SECURITY SYSTEM

50MM THK BUILT-UP ACRYLIC LETTERS (COLOR = WHITE)
WITH PAINTED ACRYLIC SIDING
(FONT = ERAS BD BT) (SIZE = 150)
AND LED LIGHT BACKLIGHTING

ROBINSONS PLACE PALAWAN S.O.

50MM THK BUILT-UP ACRYLIC LETTERS (COLOR = WHITE)
WITH OPAQUE ACRYLIC SIDING
(FONT = MONTSERRAT) (SIZE = 100)
AND LED LIGHT BACKLIGHTING

SIGNAGE TEXT DETAILS

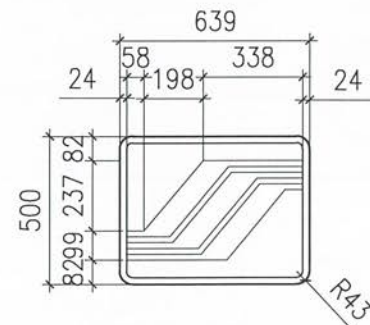

BUILT-UP ACRYLIC LOGO (COLOR = WHITE)
w/ OPAQUE ACRYLIC SIDING & LED LIGHT BACKLIGHTING

LOGO DETAILS
SCALE 1:25 m



HORIZONTAL SIGNAGE (SINGLE FACE)

SCALE 1:40 M.

*VERIFY ACTUAL SITE CONDITION, REQUIREMENTS & LOCATION OF SIGNAGE

*CERULEAN CASCADE & MARINE MIRAGE COLOR OR SIMILAR (MUST SUBMIT SAMPLE FOR APPROVAL)

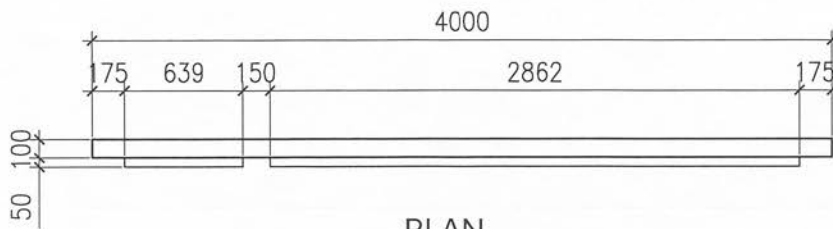

PLAN

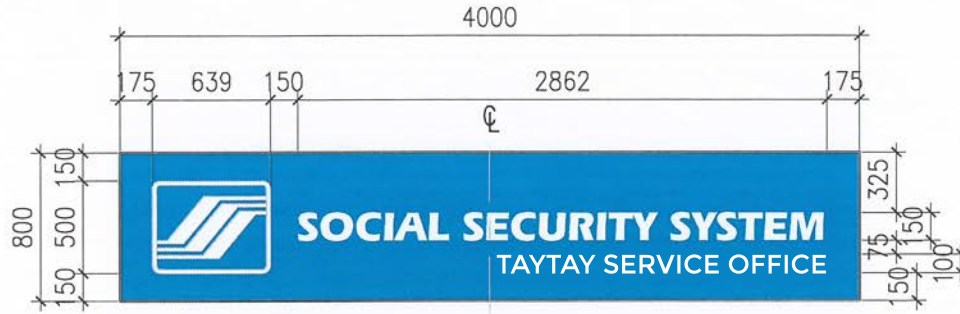

ELEVATION

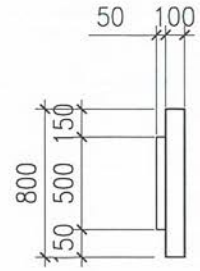

SECTION

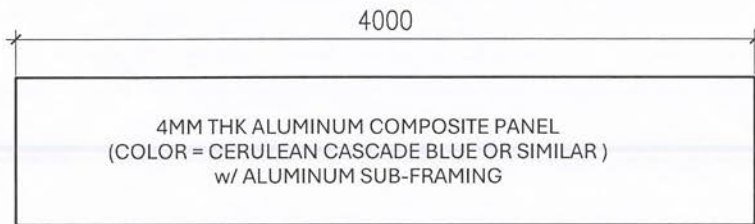

FRAME DETAILS

SOCIAL SECURITY SYSTEM

50MM THK BUILT-UP ACRYLIC LETTERS (COLOR = WHITE)
WITH PAINTED ACRYLIC SIDING
(FONT = ERAS BD BT) (SIZE = 150)
AND LED LIGHT BACKLIGHTING

TAYTAY SERVICE OFFICE

50MM THK BUILT-UP ACRYLIC LETTERS (COLOR = WHITE)
WITH OPAQUE ACRYLIC SIDING
(FONT = MONTSERRAT) (SIZE = 100)
AND LED LIGHT BACKLIGHTING

SIGNAGE TEXT DETAILS

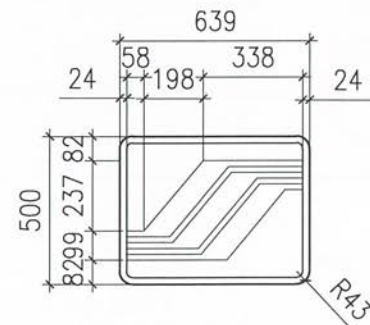

BUILT-UP ACRYLIC LOGO (COLOR = WHITE)
w/ OPAQUE ACRYLIC SIDING & LED LIGHT BACKLIGHTING

LOGO DETAILS
SCALE 1:25 m



HORIZONTAL SIGNAGE (SINGLE FACE)

SCALE 1:40 M.

*VERIFY ACTUAL SITE CONDITION, REQUIREMENTS & LOCATION OF SIGNAGE

*CERULEAN CASCADE & MARINE MIRAGE COLOR OR SIMILAR (MUST SUBMIT SAMPLE FOR APPROVAL)

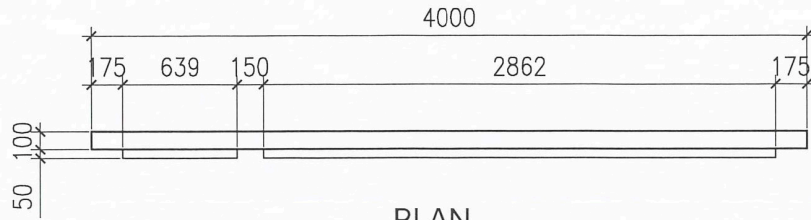

PLAN

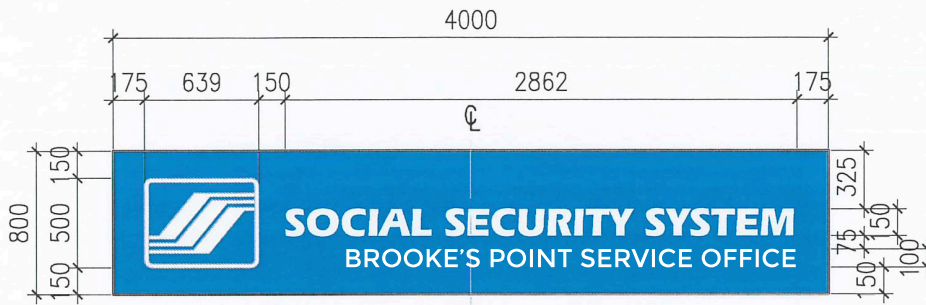

ELEVATION

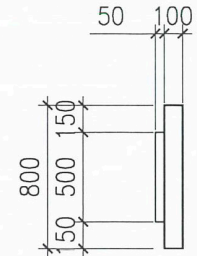

SECTION

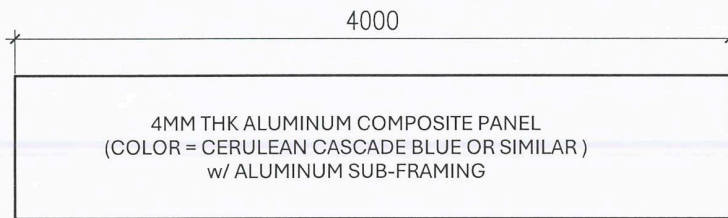

FRAME DETAILS

SOCIAL SECURITY SYSTEM

50MM THK BUILT-UP ACRYLIC LETTERS (COLOR = WHITE)
WITH PAINTED ACRYLIC SIDING
(FONT = ERAS BD BT) (SIZE = 150)
AND LED LIGHT BACKLIGHTING

BROOKE'S POINT SERVICE OFFICE

50MM THK BUILT-UP ACRYLIC LETTERS (COLOR = WHITE)
WITH OPAQUE ACRYLIC SIDING
(FONT = MONTSERRAT) (SIZE = 100)
AND LED LIGHT BACKLIGHTING

SIGNAGE TEXT DETAILS

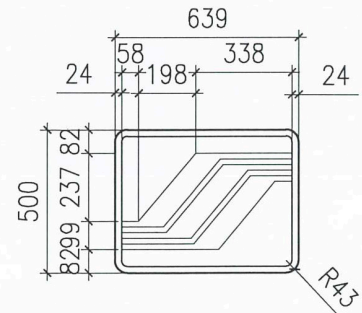

BUILT-UP ACRYLIC LOGO (COLOR = WHITE)
w/ OPAQUE ACRYLIC SIDING & LED LIGHT BACKLIGHTING

LOGO DETAILS
SCALE 1:25 m

1 HORIZONTAL SIGNAGE (SINGLE FACE)
A-04 SCALE 1:40 M.

*VERIFY ACTUAL SITE CONDITION, REQUIREMENTS & LOCATION OF SIGNAGE
*CERULEAN CASCADE & MARINE MIRAGE COLOR OR SIMILAR (MUST SUBMIT SAMPLE FOR APPROVAL)

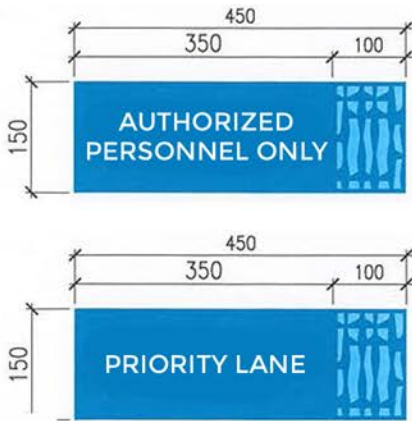

WALL & DOOR MOUNTED SIGNAGES

SINGLE FACE SIGNAGE

SIGNAGE PANEL : 3mm thk WHITE ACRYLIC SHEET BASE w/ 2mm thk CLEAR ACRYLIC SHEET COVER

DOUBLE FACE SIGNAGE

SIGNAGE PANEL : 4.5mm thk WHITE ACRYLIC SHEET BASE w/ BACK TO BACK VINYL STICKER BACKGROUND, PATTERN, AND TOP/COVER

VINYL STICKER : 3M VINYL STICKER OR EQUIVALENT

1. BACKGROUND - CERULEAN CASCADE BLUE HEX: #2B4F9B OR SIMILAR
2. PATTERN - MARINE MIRAGE HEX: #3873B6 OR SIMILAR

FONT : 25mm HIGH, MONTSERRAT FONT (CUT-OUT)

MOUNTING (VARIES)

1. PROJECTION/OVERHANG : STAINLESS STEEL PROJECTING STAND OFF BOLT OR MATTE BLACK METAL BRACKET
2. WALL/DOOR MOUNTED : HEAT-RESISTANT DOUBLE-SIDED TAPE, HEAVY DUTY
3. CEILING MOUNTED : STAINLESS STEEL CEILING-MOUNTED CABLE SIGNAGE HANGER W/ ADJUSTABLE CLIP/CLAMP

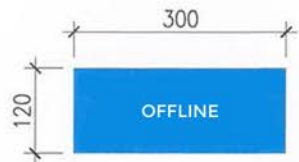

GLASS MOUNTED SIGNAGE:

- SIZE : 120mm W X 300mm H
 BASE : 3mm thk WHITE ACRYLIC PLASTIC
 COVER : LAMINATED CLEAR VINYL STICKER
 CONTENT : 3M VINYL STICKER w/ CERULEAN CASCADE BACKGROUND and WHITE w/ CUT-OUT LETTERS
 TEXT HEIGHT & STYLE : 18mm H, MONTSERRAT
 MOUNTING : SUCTION HOOK TO BE MOUNTED ON ENTRANCE GLASS DOOR OR HEAVY DUTY CLEAR, DOUBLE SIDED ADHESIVE TAPE

GLASS MOUNTED SIGNAGE - STOREFRONT



- TEXT : 3M VINYL CUT-OUT STICKER
 TEXT COLOR : CERULEAN CASCADE BLUE (HEX: #2B4F9B) OR SIMILAR
 TEXT HEIGHT & STYLE : 25mm, MONTSERRAT

GLASS DOOR SIGNAGE - VINYL STICKER CUT-OUT